

*5th Annual*  
Redneck Round-Up  
Demolition Derby  
**PICK UP TRUCK & SUV**  
Rules & Regulations



Presented and Produced by Valley Academy for Career &  
Technology Education (VACTE)  
August 23<sup>rd</sup>, 2025  
Camp Verde Equestrian Center  
Camp Verde, AZ

# Registration & Entry Fee (See Attached Form)

Registration forms may be emailed to you or downloaded from the [www.vacte.com](http://www.vacte.com) or [www.campverdearena.com](http://www.campverdearena.com) website or email [bweir@vacte.com](mailto:bweir@vacte.com). Call Bob Weir at (928) 821-0489 for more information.

## Driver Qualifications (Minimum Age is 16\*)

You must have and show a valid picture identification at the time of registration showing your age. Those under 18 are required to have a waiver signed by a parent or guardian and a valid driver's license. (See attached participation agreement and release).

## Vehicle Eligibility

### Full Size Pickup Trucks -

Any American or foreign full size 2WD pickup trucks, SUV's. 4 X 4's permitted with one driveshaft removed. All bumpers must be OEM with a max bottom edge height of 24" above the ground.

### \*Note

**If there is any doubt as to the eligibility of your vehicle, please contact a Demolition Derby Committee member *before* preparing your car for the Derby.**

## 2025 Derby Committee

Bob Weir (928) 821-0489 Jeremy Fenstermaker (480) 433-0955

# Special Construction Information

Restructuring of vehicles beyond what is described in this document is not allowed. Intent of this event is to

**HAVE FUN. Call 1<sup>st</sup> with questions – do not assume ANYTHING**

This includes, but is not limited to, replacing factory bolts with a stronger grade, or adding additional bolts between the body and the frame.

No engine cradles, belly pans, skid plates.

**No Glass of any kind. (Window front, side, back; headlights, marker light or taillights allowed)**

Repairs will be evaluated on a case-by-case basis but must mimic as close as possible the original structure of the vehicle.

Any enclosed areas that could hide extra reinforcement will be inspected. Final determination for any question lies with the officials.

***PLEASE DO NOT LOOK FOR  
IMPLIED HIDDEN LOOPHOLES.***

Vehicles not meeting the standards as determined by the organizers and the officials will not be allowed to compete.

## Vehicle Preparation (Interior)

### Battery Box

**Battery** - Battery must be moved to the inside of the vehicle and secured to the front passenger floor area. the inside of the box and 3/8" fender washers on the underside of the car floor. Additional

sheet metal may be attached to the underside of the car floor if required due to a rusty floor surface.

**Lid/Cover** -

Must be covered with plastic or rubber

## Gas Tank & Fuel

**Location** –

Directly behind the driver's seat in cars and forward and centered in P/U beds.

**Type** –

Gas tanks must be an approved Department of Transportation (DOT) metal gas container (ex: GI cans or boat tanks).

**Capacity** –

6 Gallons maximum.

**Securing** –

The gas tank must be fastened with metal straps (no plumbers tape) or chains (1/4" minimum) which are bolted securely to the floor at four points. Under body washers or metal doublers may be used to strengthen the mounting location. Bottom of tank must be surrounded on four sides by metal bracing secured to the floor so the tank cannot shift location (ex: angle iron or square tubing – see illustration). You can add other protection to the gas tank as needed for safety.

**Fuel Lines** –

Steel when possible – SAE approved rubber fuel line otherwise. Clamps are required at any joined location. At any location where lines pass through the body, heater hose (secured with duct tape), will surround the line at least 3" in each direction. **Fuel line shut off valve is recommended to located by the gas tank for easy access and safety.**

**Fuel** –

Pump gas only (no nitrous, ether or "trick" fuels).

## Safety Cage/Roll Bar

All Passenger compartments will have the minimum bracing as shown in the illustration. Bracing may not go through the passenger compartment sheet metal and fasten to the frame. The driver's side of the cage must be padded. Roll bars are recommended but are not mandatory.

### **NO EXTERNAL BODY BRACING**

**Expanded metal or straps on the driver side window and half of the windshield driver side are optional**

\* Thick black lines indicate mandatory bracing.

\* All bracing must be made of round, square or rectangular shaped tubing.

\* Size - 1 3/4" Min to 2 1/4" Max OD. Thickness - 1/8" Min.

\* Bracing must be solidly bolted or welded to the body (not the frame).

\* No bracing forward or aft of the safety cage or external to the vehicle.

- One vertical bar located in enter of windshield area. Optional: Attach to the dash bar and roof with a 12" x 12" plate for mounting –
- Please ask if you need clarification

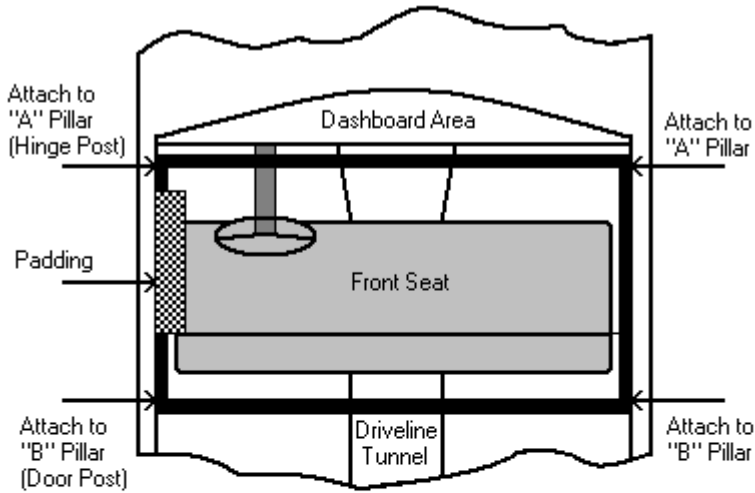

Cockpit - Top View

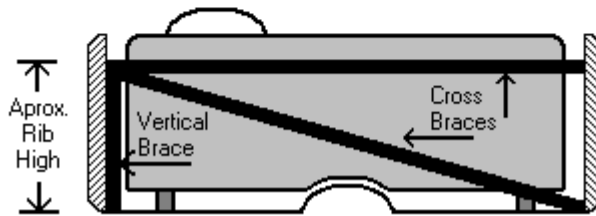

Cockpit - Rear View

•

# Truck Bed Preparation

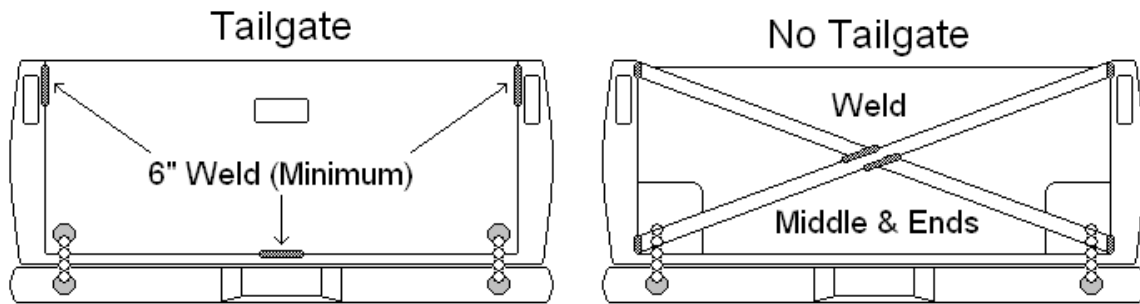

## **\*Note – Tailgates are optional!**

- If used, they will be welded a minimum of 6” on each side as shown.
- If not used, they will be replaced with X-braces as shown.
- X-braces will be welded as shown (2” pipe/square tubing max).

## **\*Note – Bumpers are optional!**

(Factory Style only – 24” max - from bottom edge to ground )

- If used, they will be secured with 5/16” chains as shown.
- Chains will pass through the tailgate or over the lower X-braces (As applicable), through the bed, then holes cut in the bumpers.

**\*Note** – There will be a minimum 6” strap welded vertically between the cab and the bed on each side joining them.

The gas tank will be mounted as shown in the center of the bed with 6” spacing from the front.

Tanks will be metal boat or GI cans with a 5 gallon maximum capacity.

The base of the tank will be framed by metal on 4 sides. The frame will be welded or bolted to the bed so it cannot move.

The tank will be bolted to the bed with 2 chains or gas tank straps as shown.

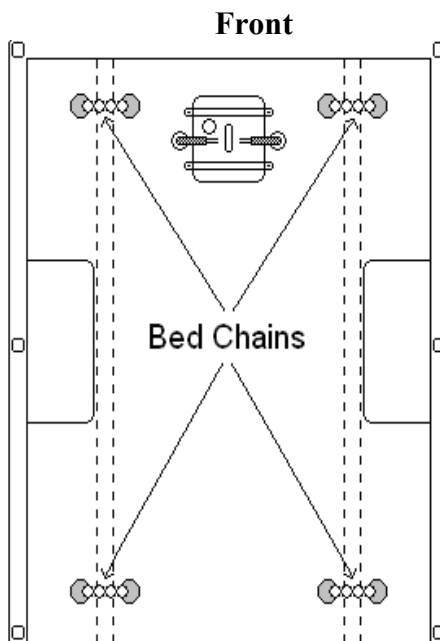

A rubber fuel line will pass through a 2” hole in the bed to join the existing steel line.

The rubber fuel line will be covered by 3/4” heater hose to the maximum extent possible and secured with tape.

A rubber vent-rollover line from the tank will exit down through the bed floor.

Bed Chains (5/16 min) will wrap through holes in the bed, around the frame and be secured in a loop at the 4 locations shown.

# Vehicle Preparation (Exterior)

**Welding** - All doors and trunks must be welded on the outside of the vehicle. Minimum welding requirements are one 6" weld per seam (doors and trunks are defined as having 3 seams, as the top of the door and the lower edge of the trunk do not count). Tailgate and hatchbacks must be welded in the closed position. Up to a 1" wide metal strap may be welded onto any seam area.

**Chassis/Frame** - Alteration of stock chassis/frame is not allowed (example: notching the frame). Trailer hitches must be removed. No welding of the frame for the express purpose of strengthening it. Repaired areas on previously run vehicles must be similar in construction, style, and material to the original. No painting or undercoating. No plating – if repairing a previously run vehicle for participation in next event, approved 3" x 5" x 3/16" plates will be allowed. If using a previously ran vehicle call about plating.

**Suspension** – Vehicle must present a level stance. Suspension cannot be raised more than stock travel will allow. No lift kits or aftermarket shackles are allowed. (To keep rear coil springs from falling out during impact, they may be welded to the axle housing only). No extra plating. Must be stock components, other than air shocks or spacers.

**Shock Absorbers/Struts** - Must be functional within their design limits.

**Rear Axle** – Must be appropriately sized for the vehicle. No gussets or bracing beyond what is necessary for installation purposes. Must be OEM style i.e., not after market. No purpose-built rear axle or drive shaft.

**Sheet Metal - Alteration** of stock sheet metal is prohibited on trucks that have not run a heat race. (Ex: creasing of rear quarter panels or notching of sail panels). No objects may be welded on the vehicle. No welding of wheel wells. Wheel wells may be cut up to 6" from the tire for clearance.

**Firewall** - Hood/chain holes will be as small as possible to allow the chains to pass through. All other holes in the firewall must be covered to prevent flames or fluid from entering the passenger area. Screw holes may be filled with silicone. Heater hose and wiring harness holes can have rubber grommets inserted to block them off. Larger holes must be covered with pieces of metal (no duct tape allowed).

**Engine Compartment** – Engines and radiators must remain in their stock location. Mechanical or electrical fans may be used or removed. The heater must be disconnected or removed. Distributor protection must not protrude forward of the engine assembly. Any mounts deemed to make car stronger not allowed. No purpose-built engines. Transmission stock type. Inspector's decision final.

## \*Note

### **No coolant allowed in radiator – water only**

**Fluid Coolers** - Coolers must be in the engine compartment. No coolers of any kind (transmission, oil, or radiator) allowed anywhere in the driver's compartment, trunk or external to the vehicle.

**Bumpers** - Any passenger car bumper may be used, no stuffed or loaded bumpers allowed no welding on the bumpers except for mounting your bumper as stated in the bumper mounting section. There will be two options for mounting your bumper, only one option can be used!

1. Bumper can be welded to original bumper shock or bracket, shock or bracket may also be welded to the frame with no more than 8 inches of weld per side, no seam welding of frames allowed, if using factory mounting brackets or shocks, they must be mounted in the factory position, must use factory mounting brackets or shocks for the vehicle you are running.

2. All factory mounting hardware may be removed and bumper may be welded directly to the end of the frame, 8x3x1/4 strap may be used in place of factory mounting hardware, no shortening of the frame. Squaring up of the frame will be allowed, only for the purpose of mounting your bumper if choosing to hardnose your bumper. Do not overdo it, or it will not run!

**Tires** –Any passenger type mud, snow, or Light Truck (LT) tires may be used. Tires will be filled with air only. **Studs in snow tires must be removed. No tractor tires are allowed.**

**Hood** -Hood may be wired, bolted or chained in 6 locations only connecting sheet metal to sheet metal. If bolting you may use 2" x 4" 1/4 angle iron with 2 3/8 bolts per spot.

**Tailgate** - **Pickup** truck tail gates must be welded in place or removed. A chain will pass through the lid/tailgate/hatchback and through the rear bumper on each corner.

## \*Note

**Chains are to be 5/16" minimum and 3/4" maximum thickness. One wrap per chain at each location maximum. Vertical chains cannot be attached to each other. No crossed chains. Chains must be connected with bolts and washers.**

**Miscellaneous** – Vehicles must be clean of all debris and loose items. This includes floor, sidewall pockets and the trunk area. Inspectors must be able to see into the trunk area and the rear of station wagons for confirmation. No sunroofs.



# Safety Equipment

**Seats** – They may be bench, bucket or racing style. They must be securely bolted or welded to the vehicle.

**Seat Belts** – Original factory style or after market seat belts with shoulder harness may be used. Racing style quick release 4- and 5-point restraints may also be used.

**Helmets & Goggles** - Motorcycle style helmets with a full-face covering are allowed. Helmets without a face cover require the use of fully enclosed plastic safety goggles. No wrap around sunglasses!

**Neck Brace** - An EMT style foam neck brace must be worn.

**Clothing** –  
Coveralls or long pants and shirts are required. Gloves are recommended.

# Race Day (Pre-Race)

**Registration** – Will be completed at the trailer located in the staging area.

**Identification** –

All drivers and pit personnel must show legitimate picture identification verifying age.

**Pit Pass Wrist Bands** –

**A maximum of 3 free pit pass wristbands per vehicle entry will be issued. If your group needs more than 3 passes, extra passes can be purchased for \$30.00 per pass.**

The minimum age for entry into the pits is 16 (15-year-olds with a valid graduated instruction permit only).

**No one is allowed in the pit area without a pit pass.**

THE AREA BY THE ANNOUNCER'S BOOTH, ARENA, FIRE TRUCKS AND AMBULANCE WHERE CARS STAGE AND ENTER THE RACE IS NOT PART OF THE PITS AND PIT PASS AREA. DRIVERS ONLY

**Inspections** -

**Will be conducted by a team of qualified and experienced volunteer inspectors. Please give them your cooperation.**

**Decisions of the Inspectors and officials are final in all cases!**

**Saturday – August 23<sup>rd</sup>      2:30 P.M. - 4:30 P.M.**

**Please bring all personal safety equipment with you for inspection.**

Upon successful completion of the inspection, a white flag will be attached to the driver's pillar post. After the driver's meeting each day, vehicles will be parked in an assigned area in the pit area where they will remain until they are raced.

**No alcoholic beverages allowed  
in the pit or inspection area at any time!**



## Race Schedule

<b>Saturday, August 23<sup>rd</sup></b>	2:30 pm	Inspections Start
	5:00 pm	Driver's Meeting
	7:00 pm	National Anthem
		Full Size Street Stock Cars Preliminaries (if Needed)
		Motorcycle Finals (2 Classes)
		Pickup & SUV
		Motorcycle Finals (2 Classes)
		Full Size Limited Weld Cars



## **Redneck Round-Up Derby Racing Basics**

### **Bring a good attitude with you!**

- \* Vehicles will line up in the staging area when their heat/class is determined.
- \* There will be a final safety check at the track entrance.
- \* The race will begin when all vehicles are on the track.
- \* Random start patterns may be selected by the track officials.
- \* An air horn blast will start and stop the race.
- \* You must hit another running vehicle at least every 2 minutes.
- \* The race will continue until the appropriate number of vehicles remain in a heat race.
- \* Stay in the car with all safety equipment on until the race ends.
  
- \* **DO NOT** hit a “dead” vehicle (flag down).
- \* **DO NOT** hit the driver’s door (white with stop sign). **Tires will be painted to help the officials with rulings. An intentional hit on a driver’s door, CAN result in being black flagged by Officials. Door hits on moving cars will be analyzed on a case-by-case basis, with multiple officials ruling, based on visibility available to the striking driver, motion of the hit vehicle and other circumstances surrounding the hit. Remember attitude is everything.**
- \* A **YELLOW FLAG**  means you have 2 minutes to move or hit another vehicle.
- \* A **RED FLAG**  means fire or emergency on the track. Stop and shut down.
- \* A **BLACK FLAG**  means you are finished. No one will be black flagged without agreement between at least 2 race officials. Pull down the white flag from the roof of your vehicle.

**The last impact delivered will determine the winner in any heat!**

### **\* Officials**

- \* They are experienced volunteers who have officiated, built cars and/or competed in the past. **They are here for your safety.** Please respect their decisions.
  - \* Please do not have contact with the officials during any race!  
They need to be focused on the track!
    - \* Be alert while racing for officials’ signals!
- \* Please REMIND all support personnel to stay out of the track area during any race  
Teams violating this rule may have their cars disqualified.
  - \* **Be safe, be smart, enjoy yourself & have fun!**  
Thank you from the officials

# Redneck Round-UP Registration Form

A separate Registration Form must be filled out for each entry

By registering a vehicle, I confirm that I have read the rules and agree to abide by them.

Vehicle#: \_\_\_\_\_ Driver's Name: \_\_\_\_\_

Sponsor's or Organization Name: \_\_\_\_\_

Mailing Address: \_\_\_\_\_

City/State/Zip: \_\_\_\_\_ Phone: \_\_\_\_\_ Email: \_\_\_\_\_

Classification: (Please select which one with an X)

\_\_\_\_ Full Size STREET STOCK Cars

\_\_\_\_ Full Size Pickup Trucks

\_\_\_\_ Limited Weld Class

Vehicle Make & Year \_\_\_\_\_

VERY BRIEF advertising statement: \_\_\_\_\_

\_\_\_\_\_

\*\*\*\*\*

ENTRY FEES: All Vehicles: *Registration + (Provide Car Number)*

### Registration Per Vehicle:

\$50.00 if submitted by July 25<sup>th</sup>, 2025

\$75.00 if submitted from July 26<sup>th</sup> through the August 8<sup>th</sup>, 2025

\$125.00 from August 9<sup>th</sup> up to 3:30 PM on August 23<sup>rd</sup>, 2025

## **NO REGISTRATIONS AFTER 3:30 P.M.!**

PAID BY CHECK: \_\_\_\_\_ CHECK#: \_\_\_\_\_

MAKE CHECKS PAYABLE TO: **Bob Weir - VACTE**

**Mail To: Bob Weir, 1951 Dodge Rd. Camp Verde, AZ 86322**

PAID IN CASH: \_\_\_\_\_

TOTAL RECEIVED: \_\_\_\_\_

PAID IN CASH: \_\_\_\_\_

TOTAL RECEIVED: \_\_\_\_\_

# Participation Agreement, Release, and Acknowledgement of Risk

In consideration of the services of VACTE, Camp Verde Arena Association (CVAA) and Town of Camp Verde, its agents, owners, officers, volunteers, participants, employees, and all other persons or entities acting on its behalf VACTE. I hereby agree to release and discharge VACTE, CVAA and Town of Camp Verde on behalf of myself, my children, my parents, my heirs, assigns, personal representatives, and estate, as follows:

I acknowledge that a DEMOLITION DERBY entails known and anticipated risks, which could result in physical or emotional injury, paralysis, death, or damage to myself, to my property, or to third parties. I understand that such risks simply cannot be eliminated without jeopardizing the essential qualities of the activity. Furthermore, VACTE/CVAA volunteers have difficult jobs to perform. They seek safety, but they are not infallible. They might be unaware of a participant's fitness or abilities. They may give inadequate warnings or instructions, and the equipment being used might malfunction.

I expressly agree, and promise, to accept and assume all the risks existing in this activity. My participation in this activity is purely voluntary and I elect to participate in spite of the risks.

I hereby voluntarily release, forever discharge, and agree to indemnify and hold harmless VACTE, CVAA. from any and all claims, demands, or causes of action, which are in any way connected with my participation in this activity, or my use of VACTE or CVAA equipment or facilities, including any such claims which allege negligent acts or emissions of VACTE or CVAA.

Should VACTE or CVAA, or anyone acting on its behalf, be required to incur attorney's fees and costs to enforce this agreement, I agree to indemnify and hold them harmless for all such fees and costs.

I certify that I have adequate insurance to cover any injury or damage I may cause or suffer while participating, or else I agree to bear the costs of such injury or damage myself. I further certify that I have no medical or physical condition which could interfere with my safety in this activity or else I am willing to assume, and bear the costs of, all risks that may be created, directly or indirectly, by any such condition.

In the event I file a lawsuit against VACTE or CVAA, I agree to do so solely in the State of Arizona, and I further agree that the substantive law of that State shall apply in that action without regard to the conflict of law rules of that State. I agree that if any portion of this Agreement is found to be void or unenforceable, the remaining portion shall remain in full force and effect.

BY SIGNING THIS DOCUMENT, I ACKNOWLEDGE THAT IF ANYONE IS HURT OR PROPERTY IS DAMAGED DURING MY PARTICIPATION IN THIS ACTIVITY, I MAY BE FOUND BY A COURT OF LAW TO HAVE WAIVED MY RIGHT TO MAINTAIN A LAWSUIT AGAINST VACTE, CVAA OR THE TOWN OF CAMP VERDE. ON THE BASIS OF ANY CLAIM FROM WHICH I HAVE RELEASED HEREIN.

I have had sufficient opportunity to read this entire document. I have read and understood it, and I agree to be bound by its terms.

Signature of Participant \_\_\_\_\_  
Print Name \_\_\_\_\_  
Address \_\_\_\_\_  
Street City State Zip  
Phone \_\_\_\_\_ Today's Date \_\_\_\_\_ Birth Date \_\_\_\_\_  
Mo. Day Year

PARENT'S OR GUARDIAN'S ADDITIONAL INDEMNIFICATION  
(Must be completed for participants under the age of 18)

In consideration of \_\_\_\_\_ (print minor's name) ("Minor") being permitted by VACTE or CVAA to participate in its activities, and to use equipment and facilities, I further agree to indemnify and hold harmless VACTE, CVAA and the Town of Camp from any and all claims which are brought by, or on behalf of Minor which are in any way connected with such use or participation by Minor.

Signature of Parent or Guardian \_\_\_\_\_

Print Name: \_\_\_\_\_ Date: \_\_\_\_\_

NOTE: ALL SIGNATURES REQUIRE NOTARIZATION.

State of Arizona  
County of Yavapai

The foregoing instrument was acknowledged before me this \_\_\_\_ day of \_\_\_\_\_ 20\_\_ by \_\_\_\_\_.

\_\_\_\_\_  
Notary Public

My commission expires: \_\_\_\_\_